

DBS Series

BATTERY ISOLATOR

COSUPER®

Reliable battery management solution, safe and dependable

Amp Range:

100A

120A

140A

160A

200A

12V & 24V



COSUPER battery isolator allows dual battery to be charged from single power supply such as alternator, battery charger or solar charger. Because of the unique ability of passing current in one direction, the first battery bank can be discharged without draining from the second battery bank.

With this isolator operating in the system, the power would not be taken from engine's battery, keep your main battery to be fully charged.

Product Features

- Microcontroller based on zero voltage drop and efficient
- 12V & 24V version for different battery system
- Customized low-voltage cutout and over-voltage protection
- Ultra low self consumption
- Protect auxiliary batteries and connected equipments against over voltage
- Start assist with optional manual switch allows the auxiliary battery assist start battery work
- Easy installation - connect start battery, auxiliary battery and ground
- Sealed unit, IP65 water proof
- 18 months warranty

Applications:



Motorhomes



Caravans



Mobile homes



Ambulance



Fire Trucks



Off Grid Solar System

COSUPER ENERGY TECHNOLOGY CO.,LTD

#18 Building
No.99, Gangtian Road
Suzhou, Jiangsu Province, China
0086 512 68638910 Phone
0086 512 68638916 Fax

www.cosuper.com

DBS Series

BATTERY ISOLATOR

Model	DBS100	DBS120	DBS140	DBS160	DBS200	DBS280
Rated voltage	12 or 24 VDC					
Maximum Current	100A	120A	140A	160A	200A	280A
Efficiency	95%					
Connect voltage	13.6-13.8VDC(for 12V battery)/ 27.2-27.6VDC(for 24V battery)					
Disconnect voltage	12.6-12.8VDC(for 12V battery)/ 25.2-25.6VDC(for 12V battery)					
Operating Temp	-20 C° ~ 50 C°					
Dimension (mm/in)	112 × 56 × 64 / 4.4" × 2.2" × 2.5"			143 × 56 × 64 / 5.6" × 2.2" × 2.5"		
Weight(kg/lb)	0.5/ 1.1	0.5/ 1.1	0.5/ 1.1	0.65/ 1.4	0.65/ 1.4	0.86/ 1.9

Loads power	<1000W	1000-2000W	2000- 3000W
Suggested auxiliary battery	150Ah	200Ah	400Ah
Suggested fuse	140A	180A	250A
Suggested model	DBS100	DBS160	DBS200

Typical vehicle wiring diagram

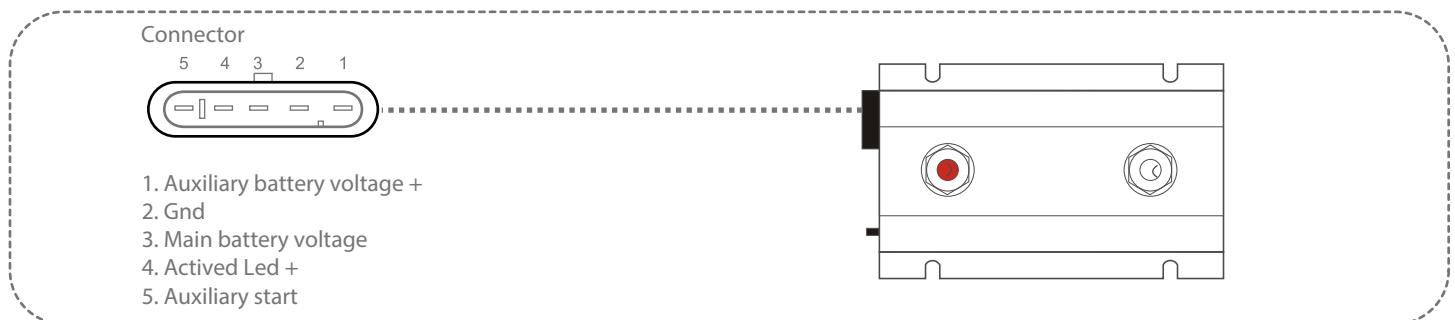
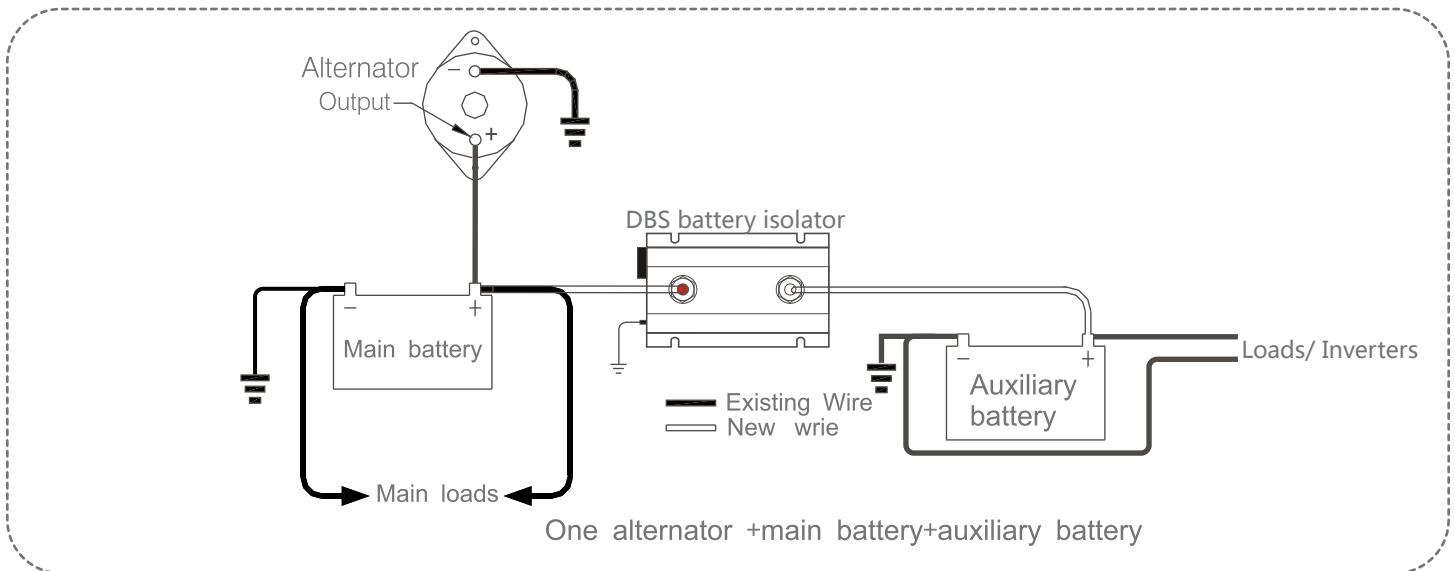

* Specifications are subject to change without notice